

THE 9TH GENERATION MEANS PERFECTION



INSERTING:
9G SERIES

Since introducing the first generation of today's 9G inserting system in 1976, BOWE SYSTEC has continuously enhanced and improved its concept. For the design of the ninth generation, the focus was on energy-efficiency and the reliability of the production process. A whole host of technical improvements help the 9G series satisfy these market requirements and make it the most eco-friendly system in its class. Alongside all these innovations, the system retains many proven features such as vertical transport to ensure gentle and stable handling or the use of pneumatic and servo technologies as well as minimal set-up times through fully automated job changeovers. All of this combines to deliver the highest level of integrity at throughputs of up to 26,000 envelopes per hour.

TOP PERFORMANCE THROUGH EXPERIENCE

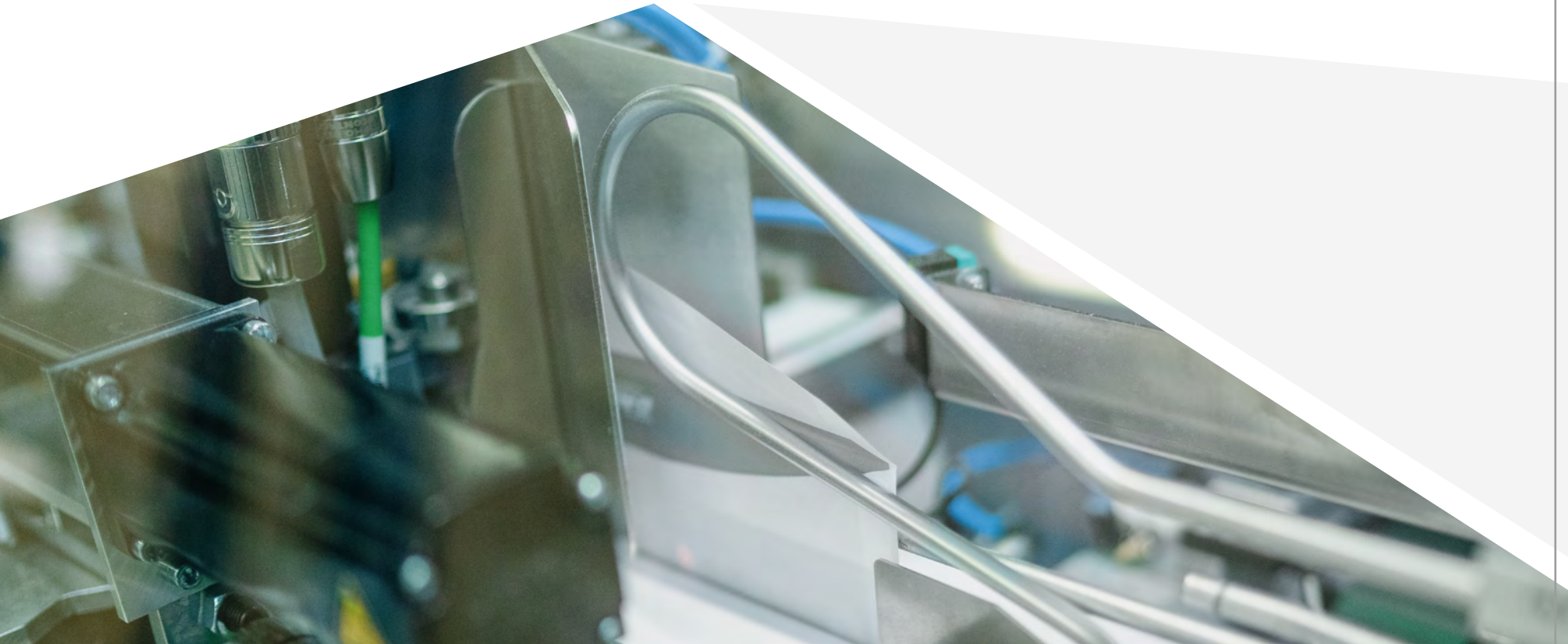

✓ **IDEAL FOR TRANSACTIONAL MAIL**

✓ **FAST, RELIABLE, EFFICIENT**

✓ **FLEXIBLE & MULTI-FUNCTIONAL**

✓ **STABLE PROCESSING THANKS TO PNEUMATIC & SERVO TECHNOLOGIES**

✓ **ECO-FRIENDLY, ENERGY-EFFICIENT**

9G SERIES AT A GLANCE

9G



High volumes



Market-proven & mature technology



Total flexibility & full modularity



Maximum integrity

9G BASIC



High volumes with low page count/envelope



Proven 9G technology



3 powerful, standardized infeed channel options at an attractive price

m²

Small footprint

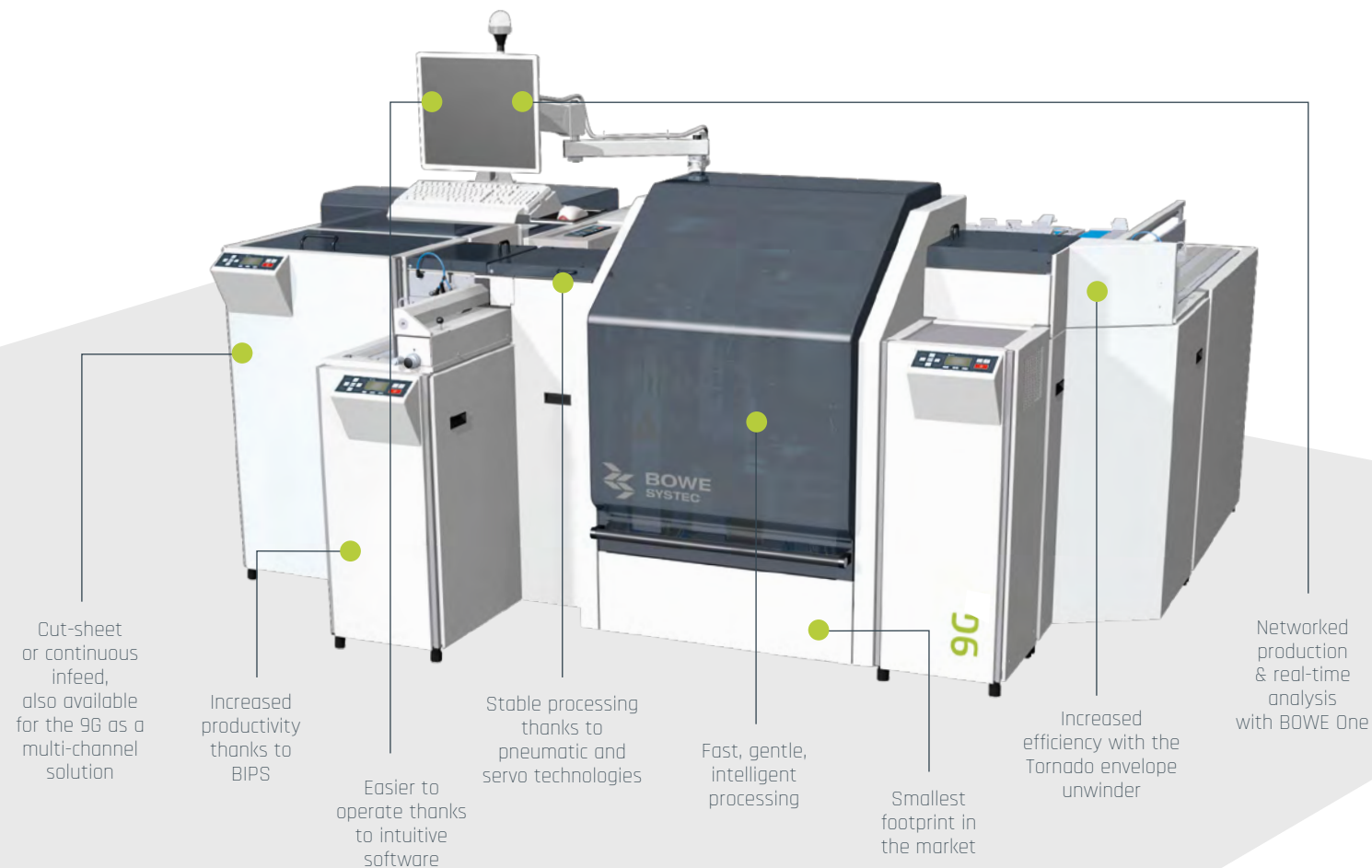

Cut-sheet or continuous infeed, also available for the 9G as a multi-channel solution

Increased productivity thanks to BIPS

Easier to operate thanks to intuitive software

Stable processing thanks to pneumatic and servo technologies

Fast, gentle, intelligent processing

Smallest footprint in the market

Increased efficiency with the Tornado envelope unwinder

Networked production & real-time analysis with BOWE One

 Fast, gentle, reliable and intelligent processing at up to 26,000 envelopes per hour

 Full modularity for multifunctional use and adaptability to spatial requirements and processes

 Simple handling and efficient processing with 100 percent integrity

 Despite its extremely small footprint, the 9G Basic boasts the capabilities of a high performance system

 Minimal changeover times and increased productivity thanks to BIPS

 As the standardized special model in the 9G Series, the 9G Basic delivers high performance for a moderate investment

MAXIMUM POWER MINIMUM SPACE

From insurers through telecommunication or energy providers to public authorities: wherever speed, integrity, stability and cost-efficiency matter, a high performance 9G Series inserter is always first choice. Outstandingly energy-efficient and eco-friendly, these inserters are superb at dealing with high volume transactional jobs.

The modular design and flexibility of the 9G inserting system leave virtually no wish unfulfilled in the mailroom. The 9G handles a wide variety of applications reliably, allowing you to choose between a top speed of either 22,000 or 26,000 envelopes per hour. Thanks to its full modularity and numerous options, the multi-functional 9G adapts readily to both the space available and existing processes.

The 9G Basic is a special model offering the same processing reliability and integrity as the 9G combined with maximum availability, productivity and ease of maintenance. However, the 9G Basic is restricted to assembly after folding, deliberately focusing on the essentials so as to give even smaller companies extremely high performance at an attractive price. This fast, entry-level system packs an awful lot of power into a footprint of just 12 m² in its smallest configuration. Yet despite its compact size, the 9G Basic integrates the capabilities of a high performance system and the vast majority of applications to be found in a mailroom are no problem. The 9G Series: inserting systems for every transactional requirement!



RECORD-BREAKER

BOWE SYSTEC has constantly developed this system ever since the first version of today's 9G inserting system was launched back in 1976. Even in its early days, the System 501 created something of a stir in the market and at the time was the world's fastest inserting system with a speed of 12,500 envelopes per hour – an achievement that earned it a place in the Guinness Book of Records. Meanwhile delivering up to 26,000 envelopes per hour, it continues to be one of the fastest inserting systems on the market. Maximum power, minimum space!

MORE ABOUT POWERFUL 9G







9G SERIES AT A GLANCE

9G

-  High volumes
-  Market-proven & mature technology
-  Total flexibility & full modularity
-  Maximum integrity

9G BASIC

-  High volumes with low page count/envelope
-  Proven 9G technology
-  3 powerful, standardized infeed channel options at an attractive price
-  Small footprint

HOW TO BUILD AN INSERTER

Mailroom requirements are becoming ever more complex and the need for machines to be flexible has never been greater. The modular design of the 9G means that it can be adapted both to the available space and to existing processes. From the compact and affordable basic version to the sophisticated, high-performance system for complex tasks, 9G represents the perfect solution for every application and every print and mail production center.

Configured using standardized components in the infeed channel from the mature and market-proven 9G system, the 9G Basic combines simple handling with efficient processing – plus maximum integrity. The machine is particularly suitable for inserting jobs with low page counts and packs an awful lot of power into a small footprint. It is one of the smallest and, at up to 26,000 envelopes per hour, fastest systems in its class – and all at an extremely attractive price.

9G

9G

TOP PERFORMANCE THROUGH EXPERIENCE



High volumes



Market-proven & mature technology



Total flexibility & full modularity



Maximum integrity

TECHNICAL SPECIFICATIONS

Envelope formats	C6 - C5 #7 3/4 - 6 x 9
Max. speed	26,000 env/h
Max. enclosure thickness	1.8 mm 0.08"
Number of channels	≥ 1 channel
Max. filling thickness	7 mm 0.28"

9GBASIC

9G BASIC

KEEP IT SIMPLE AT HIGH SPEED



High volumes with low page count/envelope



Proven 9G technology



3 powerful, standardized infeed channel options at an attractive price



Small footprint

TECHNICAL SPECIFICATIONS

Envelope formats	C6 - C5 #7 3/4 - 6 x 9
Max. speed	26,000 env/h
Max. enclosure thickness	1.8 mm 0.08"
Number of channels	1 channel
Max. filling thickness	7 mm 0.28"

9G SERIES AT A GLANCE

9G



High volumes



Market-proven & mature technology



Total flexibility & full modularity



Maximum integrity

9G BASIC



High volumes with low page count/envelope



Proven 9G technology



3 powerful, standardized infeed channel options at an attractive price



Small footprint

THE 9G INSERTING PRINCIPLE

9G Series inserters offer the highest integrity and productivity for high volume mail processing. Their vertical material transport ensures secure guiding and fast, precise handling of documents. This process is gentle not only on the material but also on the machine, which in turn guarantees reliable performance in the long term. Pneumatic and servo technologies likewise contribute to reliable processing. Transport speeds have been harmonized for the 9G Series, improving stability and allowing processing of higher print volumes in a short time. Maximum integrity is achieved by utilizing sensors to locate and identify each and every document within the system.

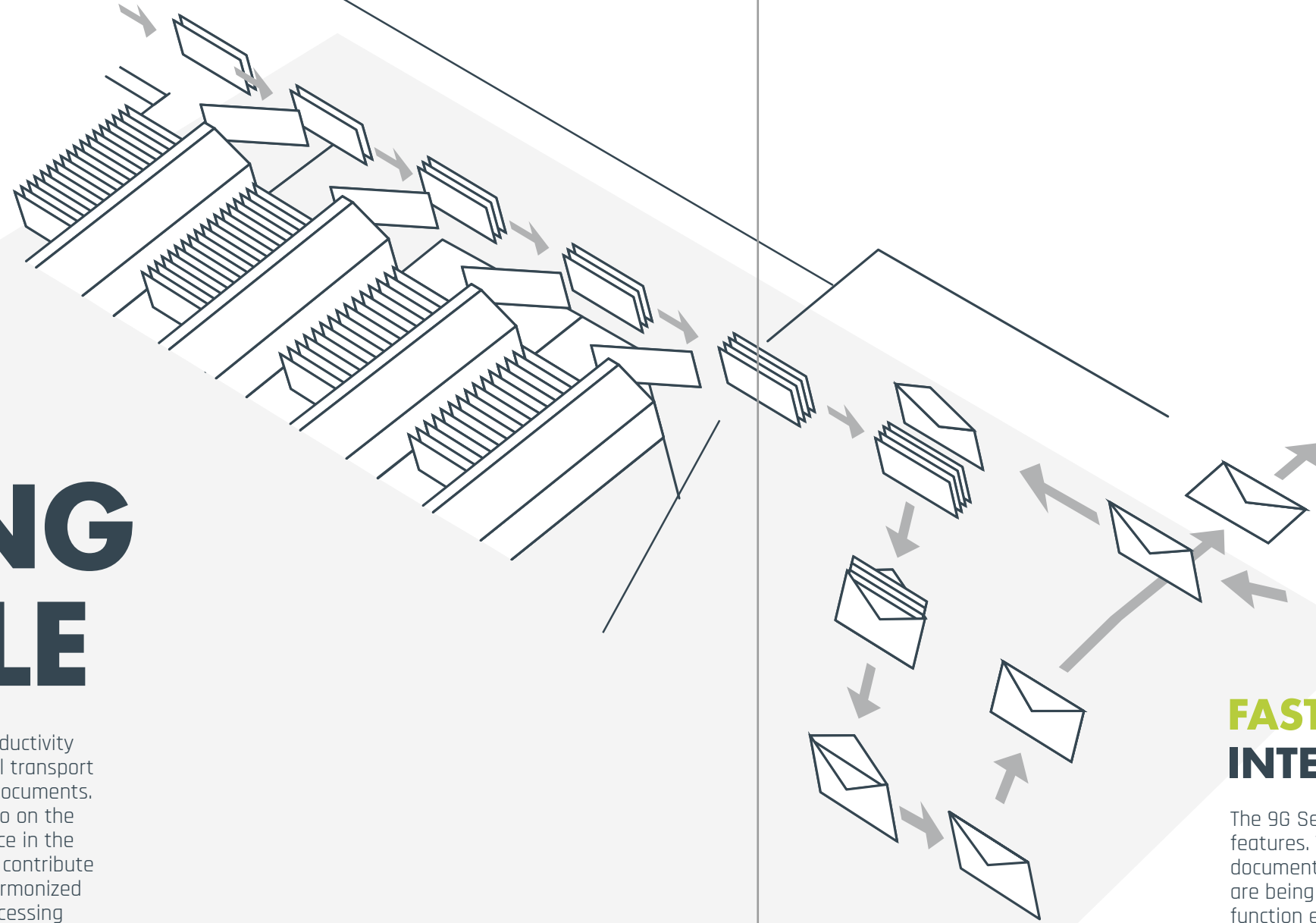

FAST, GENTLE, INTELLIGENT

The 9G Series also scores with its intelligent features. The speed adjusts to the thickness of the document sets, slowing down when thicker sets are being processed. An event-triggered stop function ensures that the system only stops when absolutely necessary and fault tolerant operation means several draw-off attempts are possible without stopping the system. Pneumatic and servo technologies provide stable and gentle material handling even at high speeds.



ONE SYSTEM TWO SPEEDS

A special feature, is its available at two different speeds. With a performance of up to 26,000 envelopes per hour, the 9G 26k is perfect for single-channel applications and high volume jobs with a low page count per envelope. The competitively priced 9G 22k achieves up to 22,000 envelopes per hour and is ideal for complex single- and multi-channel applications or high volume jobs. If the requirements in a mailroom change, an upgrade from the 9G 22k to the 26k is possible at any time.

MORE
ABOUT
9G



9G SERIES AT A GLANCE

9G

- High volumes
- Market-proven & mature technology
- Total flexibility & full modularity
- Maximum integrity

9G BASIC

- High volumes with low page count/envelope
- Proven 9G technology
- 3 powerful, standardized infeed channel options at an attractive price
- Small footprint



NO RISK, NO FUN? NOT WITH US!

When sending official documents that may contain sensitive, personal information, data protection and integrity during processing become even more important. 9G Series inserting systems don't just offer exceptional performance, their use of the latest software enables them to fulfil the most stringent integrity and data protection requirements. Reading units and sensors ensure seamless tracking of items throughout the entire production process. Play it safe with us!

MINIMAL SETUP TIMES MAXIMUM OUTPUT

9G Series inserters can optionally be equipped with the BOWE Intelligent Productivity System (BIPS). This technology allows setup times to be substantially reduced, and production performance increases significantly as a result. BIPS makes it possible to set the entire system up for a new application in the minimum of time. Thanks to the memory function, saved job data can be called up again whenever it is needed. Automated job changeover driven by BIPS, which is available for many BOWE SYSTEC systems, saves valuable time and results in higher system availability. A clearly structured and self-explanatory input mask for the system control software allows the operator to set up a new application within minutes and without the inserting system requiring any manual intervention. Changes in form size or type of fold can be implemented by means of motorized adjustments to the system components. This guarantees reproducible job settings and simplifies system operation.

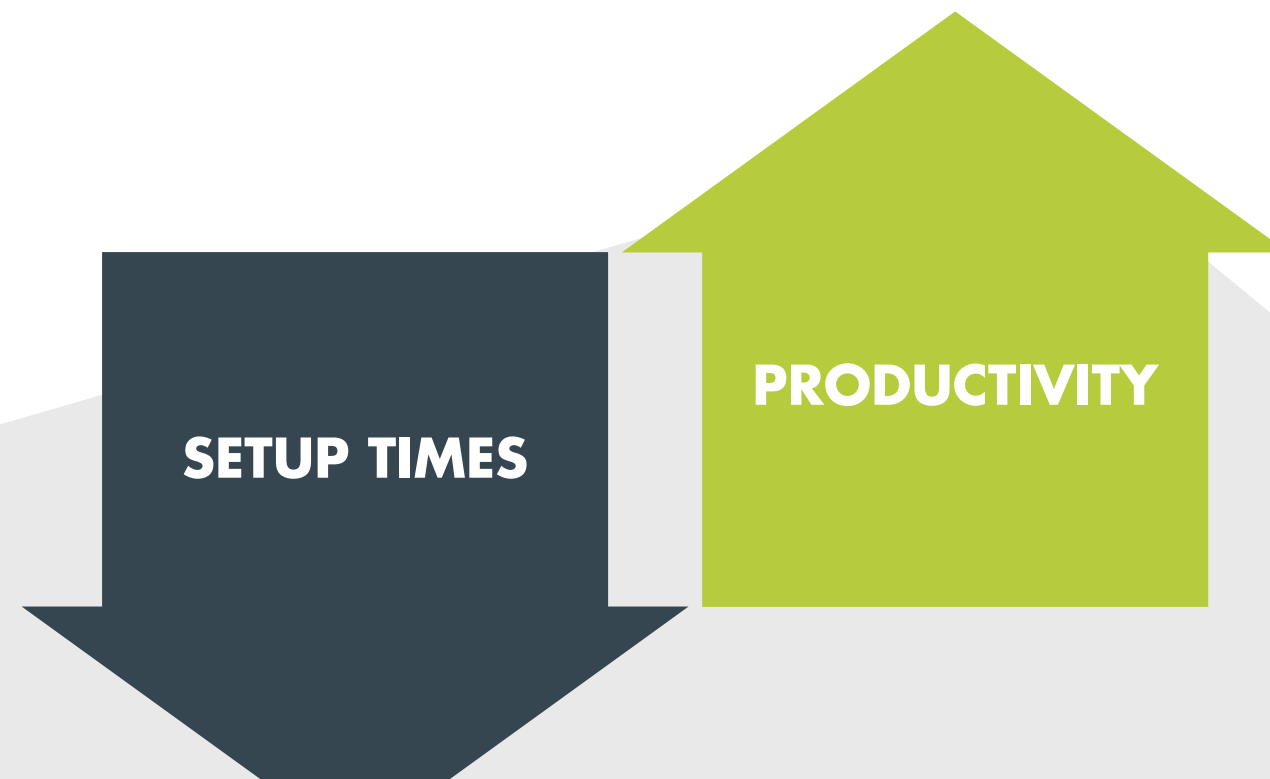

9G SERIES AT A GLANCE

9G



High volumes



Market-proven & mature technology



Total flexibility & full modularity



Maximum integrity

9G BASIC



High volumes with low page count/envelope



Proven 9G technology



3 powerful, standardized infeed channel options at an attractive price

m²

Small footprint

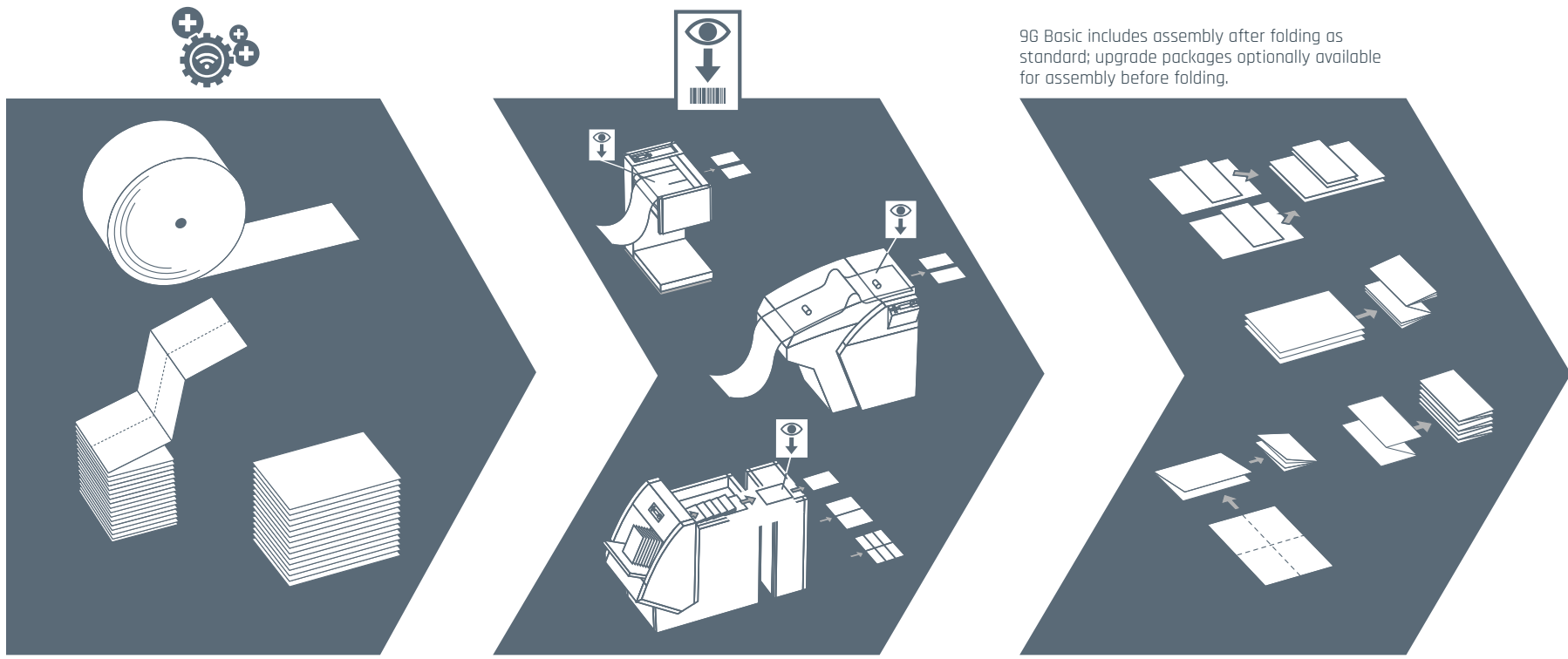

Flexible document feeding & merging

Reliable document processing

9G Basic includes assembly after folding as standard; upgrade packages optionally available for assembly before folding.

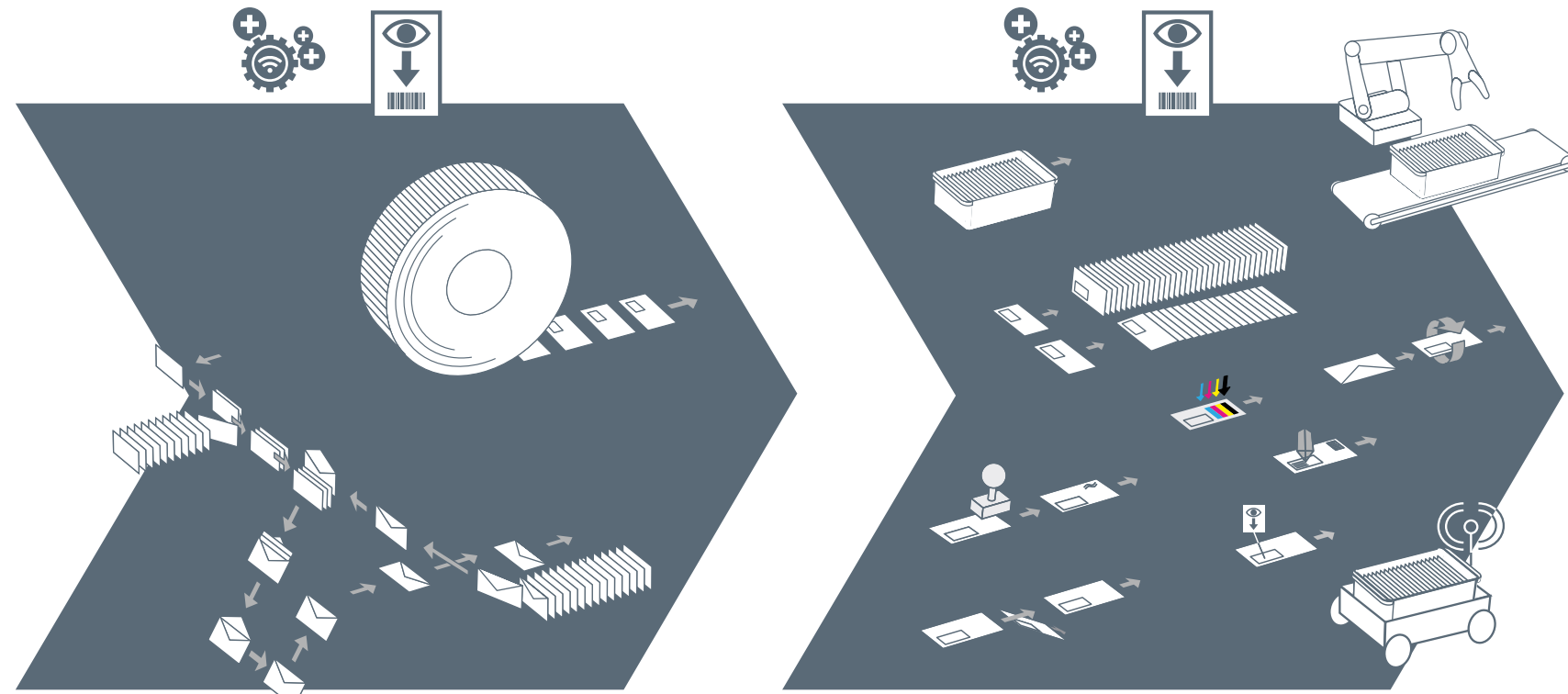

Options for optimal enclosure and envelope processing

Enhanced automation options

CUSTOMIZED PERFORMANCE PACKAGES

The 9G Series offers the ultimate in integrity, flexibility and productivity for high volume mail processing. From document infeed through enclosure processing and inserting to post-processing, every step is perfectly integrated with the others. Other BOWE SYSTEC technologies allow you to integrate and automate upstream or downstream stages and turn your mailroom into the mail production center of your dreams.

HIGH PERFORMANCE SOFTWARE

BOWE SYSTEC offers smart, flexible software solutions throughout its entire product range, ensuring you are ideally equipped to tackle the production tasks of tomorrow - from intuitive machine control via the modern software platform Orbiter and production monitoring right up to process-optimizing warehouse management systems. Driving efficiency forward!



Process-optimizing software (Warehouse Management Systems)

9G SERIES AT A GLANCE

9G

- High volumes
- Market-proven & mature technology
- Total flexibility & full modularity
- Maximum integrity

9G BASIC

- High volumes with low page count/envelope
- Proven 9G technology
- 3 powerful, standardized infeed channel options at an attractive price
- m² Small footprint

Some features optional.

Thanks to their modular design and broad range of options, 9G Series inserting systems can be individually configured to meet your specific requirements or easily upgraded at a later date.

STAY FLEXIBLE

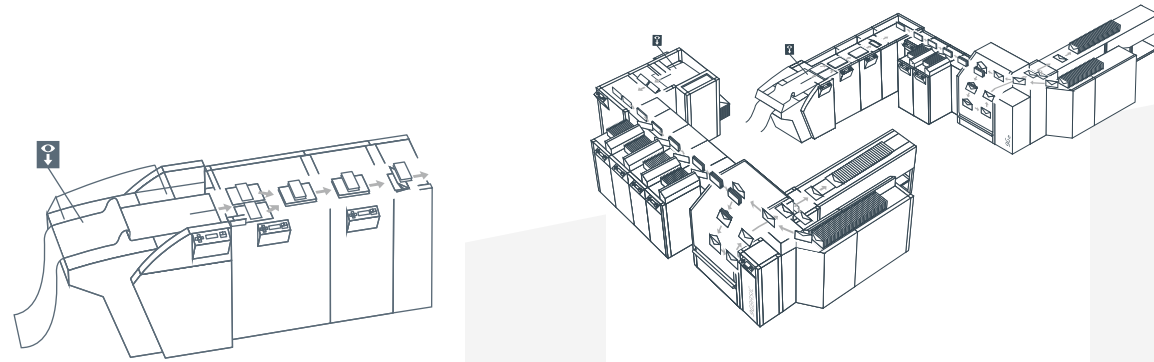

High performance from A to Z

Whether cut-sheet or continuous processing - input channels for different performance ranges make the 9G Series perfect systems to have by your side. The high-speed infeed channel is capable of feeding up to 100,000 sheets/h* to guarantee top performance. 9G systems are also multi-channel ready with patented auto-synchronization.

Flexible sequencing

Requirements in a mail production center are becoming ever more complex and the need for machines to be flexible keeps on growing. The versatility of the 9G begins with its infeed, where the newly developed sequencer allows the system to be effortlessly adapted to existing printing and mailroom processes.

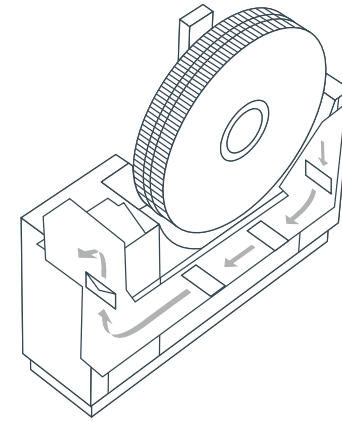

Tornado creates a stir in any mailroom

The Tornado unwinder for continuous envelope infeed promises significant efficiency improvements for the mailroom. It can automatically feed a continuous flow of C5, C6/5, DL as well as 6 x 9 and #10 envelopes into the inserter over a prolonged period of time, reducing operator workload, and for long runs with standard envelopes it is virtually a must-have.

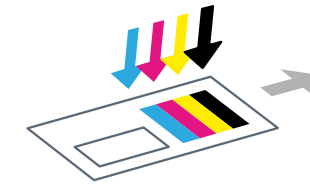

EPOD for brilliant four-color envelope printing

Envelope Print On Demand (EPOD) allows logos or individual marketing messages to be printed directly on the envelope in full color, opening up completely new possibilities for attracting attention and increasing efficiency. What's more, it is no longer necessary to store pre-printed envelopes, which simplifies intralogistics.

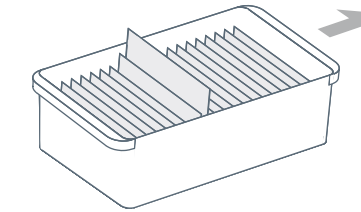

BOXIT postal tray system: Efficient letter logistics





Automation taken a step further: BOXIT is a smart system for automatically filling postal trays that is optionally available for 9G Series systems. It takes the envelopes filled by the inserter and places them into mail bins. In combination with a 9G system, BOXIT enables speeds of up to 26,000 envelopes/h and makes our fast inserters more efficient and easier to operate.

9G SERIES AT A GLANCE

9G

-  High volumes
-  Market-proven & mature technology
-  Total flexibility & full modularity
-  Maximum integrity

9G BASIC

-  High volumes with low page count/envelope
-  Proven 9G technology
-  3 powerful, standardized infeed channel options at an attractive price
-  Small footprint

Some features optional.

9G BASIC: POWERFUL STANDARDS

Small, fast, chic and very attractively priced: the 9G Basic. As the smallest and yet, at 26,000 envelopes per hour, fastest in its class, it is the ideal entry-level machine for the high performance segment. Since 9G Basic only offers assembly after folding, it is ideal for jobs with a low page count per envelope. Depending on the type of material to be processed, 9G Basic is available in three standard infeed channel configurations. Additionally, there are the enclosure feeders, the powerful inserting module of the latest 9G inserting system and the corresponding envelope feeding and stacking components.

TECHNICAL SPECIFICATIONS FOR DOCUMENTS FROM THE INFEED CHANNEL VALID FOR 9G BASIC

Configuration	Processing	Pinfeed	Pinless	1-up	2-up	Width	Height	Weight
I	Continuous	•			•	148 - 220 mm (2-up)	3.5" - 16"	70 - 160 g/m ²
II	Continuous		•		•	148 - 220 mm (2-up)	3.5" - 16"	70 - 160 g/m ²
III	Cut-sheet			•		210 - 220 mm (1-up)	8" - 14"	70 - 160 g/m ²

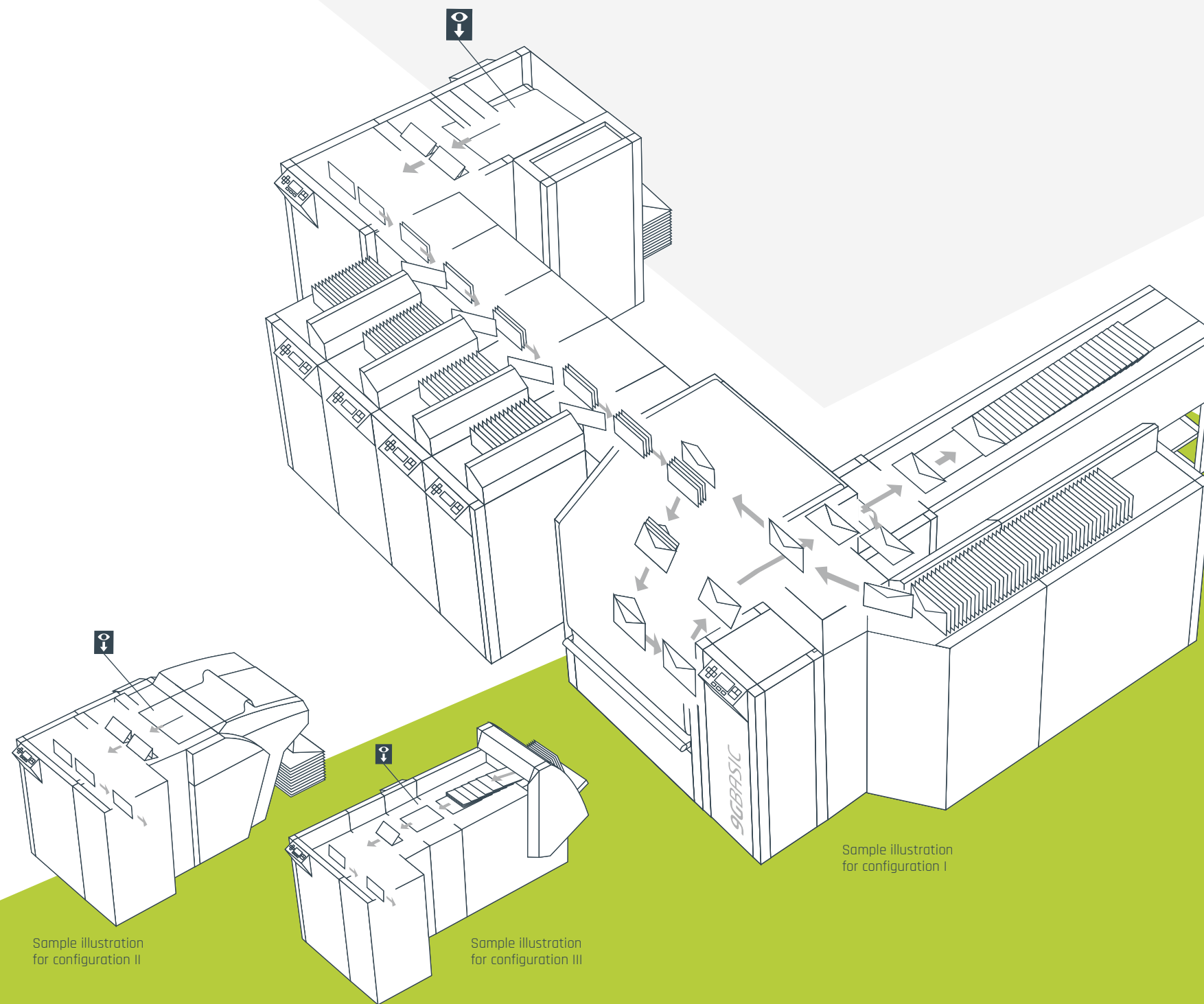

Sample illustration for configuration II

Sample illustration for configuration III

Sample illustration for configuration I

9G SERIES AT A GLANCE

9G

- High volumes
- Market-proven & mature technology
- Total flexibility & full modularity
- Maximum integrity

9G BASIC

- High volumes with low page count/envelope
- Proven 9G technology
- 3 powerful, standardized infeed channel options at an attractive price
- Small footprint



**MORE ABOUT OUR
SOFTWARE DIVISION**
BOWE IQ



MODERN SOFTWARE FOR TOMORROW'S PRODUCTION

9G Series systems are centrally controlled by means of our intuitive control software. The modern design of the clearly structured and easy-to-understand user interface speeds up both job programming and operation. The machine control software also enhances reporting and serves as the foundation for increased system productivity.

BOWE One offers a host of central, cross-system inserting functions. Unlock the benefits of networked production and optimize your processes across systems and sites on the basis of precise, real-time data. Database-controlled production also guarantees that you never miss a thing; seamless item tracking delivers 100 percent process integrity.

9G SERIES AT A GLANCE

9G



High volumes



Market-proven & mature technology



Total flexibility & full modularity



Maximum integrity

9G BASIC



High volumes with low page count/envelope



Proven 9G technology



3 powerful, standardized infeed channel options at an attractive price



Small footprint



24/7

BY YOUR SIDE WORLDWIDE

A high-quality product requires first-class service. That's why we cover the world for you from our headquarters in Augsburg and through our network of about 20 subsidiaries and over 50 general representatives across the globe. Our local service presence helps you maximize your productivity and minimize your downtime. BOWE SYSTEC gives you a dedicated contact who speaks your language and who is reachable 24/7. Short travel distances also mean quick, unbureaucratic support. We are by your side anywhere in the world to make sure your mail production center keeps on running.

**FIND YOUR
LOCAL CONTACT
HERE**



LEGAL NOTICE

BÖWE SYSTEC GmbH
Werner-von-Siemens-Str. 1
86159 Augsburg | Germany
Phone +49 821 5702-0
Fax +49 821 5702-234
info@bowe.com
www.bowe.com

Managing Director: Joachim Koschier

Registered Office: Lübeck
Company Registration No.: HRB 10736 HL

VAT Reg. No. in accordance with section 27 a
Value Added Tax Law: DE 274185634

Responsible for content in accordance
with § 18 (2) of the German Interstate
Media Treaty (MStV): Joachim Koschier

All rights reserved. Errors and omissions excepted.
Images for guidance only.

@ BÖWE SYSTEC GmbH

9G SERIES AT A GLANCE

9G



High volumes



Market-proven & mature technology



Total flexibility & full modularity



Maximum integrity

9G BASIC



High volumes with low page count/envelope



Proven 9G technology



3 powerful, standardized infeed channel options at an attractive price

m²

Small footprint

SMART AUTOMATION SOLUTIONS

Our smart automation solutions have been optimizing workflows and production processes for decades in many different industries. Take advantage of our many years of mail production center experience and find the perfect solution for your requirements.



**MANY YEARS
OF EXPERIENCE**



**FUTURE-PROOF
INVESTMENT**



**BY YOUR SIDE
WORLDWIDE**



**CUSTOMIZED
SOLUTIONS**

**VISIT US AT
[BOWE.COM/SYSTE](https://www.bowe.com/systec)**



**MORE INFO AT
[BOWE.COM](https://www.bowe.com)**

developed by
**BOWE
GROUP**